

DC Power Module, 241W or 460W – UTC014

241W or 460W DC Power Module

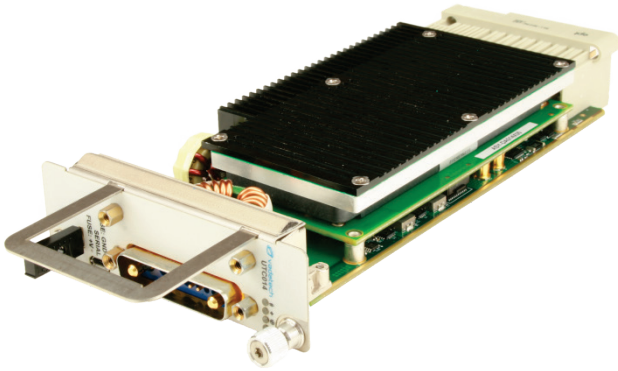

KEY FEATURES

- Single module, full-size per AMC.0
- 10 to 36 VDC input for 241W option and 18 to 36 VDC input for 460W option
- Support for power module redundancy
- Dual IPMI bus
- 32-bit RISC processor
- Two banks of 256K flash for redundancy
- Field upgradable
- IPMI 2.0 compliant
- HPM.1 compliant
- Without the presence of an MCH the modules can be turned on
- Menu driven software for ease of configuration
- Current measure for each module
- External as well as internal WDT

μTCA™

Benefits of Choosing VadaTech

- Very low ripple voltage
- Support for power module redundancy
- Efficient re-use of existing designs/components reduce costs
- Electrical, mechanical, software and system-level expertise in house
- Full ecosystem of front and rear boards, enclosures, speciality modules, and test/dev product from one source

The VadaTech UTC014 is a 241/460W power module for use in a μTCA chassis. The power module runs at 84% efficiency when running at maximum load. This results in 200/400W (available to the system). It is fully compliant with the MicroTCA.0 and MicroTCA.1 specifications; including dual-redundant I²C buses (IPMB-0).

The UTC014 is fully redundant when used in conjunction with a second instance of the module. It provides power to the twelve slots, two MCHs (MicroTCA Carrier Hubs) as well as the CUs.

Multiple temperature sensors are included on-board to monitor for over-temp conditions within the module. The current is continuously measured for each of the modules and reported to MCH for any fault.

The firmware is upgradable via HPM.

VadaTech can modify this product to meet special customer requirements. Contact us to discuss your application.

SPECIFICATIONS

Architecture		
Physical	Dimensions	Width: 2.89" (73.5 mm)
		Depth 7.11" (180.6 mm)
Type	AMC Power Module	Intelligent power controller for μ TCA chassis, single
Standards		
Module Management	IPMI	IPMI version 2.0
	AMC	PICMG AMC.0 Revision 1.0 (AdvancedMC)
	μ TCA	PICMG MicroTCA.0 Revision 1.0
	ATCA	PICMG 3.0 Revision 2.0 (AdvancedTCA)
	HPM	HPM.1 Revision 1.0
Power	UTC0014	241/460 W
Environmental	Temperature	Operating Temperature: -5° to 55°C (air flow > 400LFM) industrial and military versions also available (See environmental spec sheet) Storage Temperature: -40° to +85°C
	Vibration	1G, 5 to 500Hz on each axis
	Shock	30Gs on each axis
	Relative Humidity	5 to 95 per cent, non-condensing
	Front Panel	External Interface
	LEDs	IPMI management control: blue, red, amber, green and fuse indicator for each input rail
	Mechanical	Hot swap handle
	Input Power	10 to 36V DC for 241W option and 18 to 36V DC for 460W option
	Temperature Sensor	Multiple temperature sensors on-board
Other		
MTBF	MIL Hand book 217-F @ TBD Hrs	
Certifications	Designed to meet FCC, CE and UL certifications where applicable	
Standards	VadaTech is certified to both the ISO9001:2000 and AS9100B:2004 standards	
Compliance	RoHS and NEBS	
Warranty	Two (2) years	
Trademarks and Disclaimer	The VadaTech logo is a registered trademark of VadaTech, Inc. Other registered trademarks are the property of their respective owners. AdvancedTCA™ and the AdvancedMC™ logo are trademarks of the PCI Industrial Computers Manufacturers Group. All rights reserved. Specification subject to change without notice	

IPMI FUNCTIONALITY

The UTC014 is IPMI 2.0 and HPM.1 compliant with optional IPMI commands including warm/cold reset, re-arm sensor events, get device GUID, and get/set the hysteresis, threshold, and/or sensor event enable. The PMs follow the ATCA specification in fail-over for redundant IPMB-0 and FRU LED control. The units also have power channel control, get power channel status, PM reset, get PM status, and PM heartbeat. Temperature and current sensors are also included.

INTEGRATION SERVICES AND APPLICATION-READY PLATFORMS

VadaTech has a full ecosystem of ATCA and μ TCA products including chassis platforms, shelf managers, AMC modules, Switch and Payload Boards, Rear Transition Modules (RTM), Power Modules, and more. The company also offers integration services as well as pre-configured Application-Ready Platforms. Please contact VadaTech Sales for more information.

BLOCK DIAGRAM

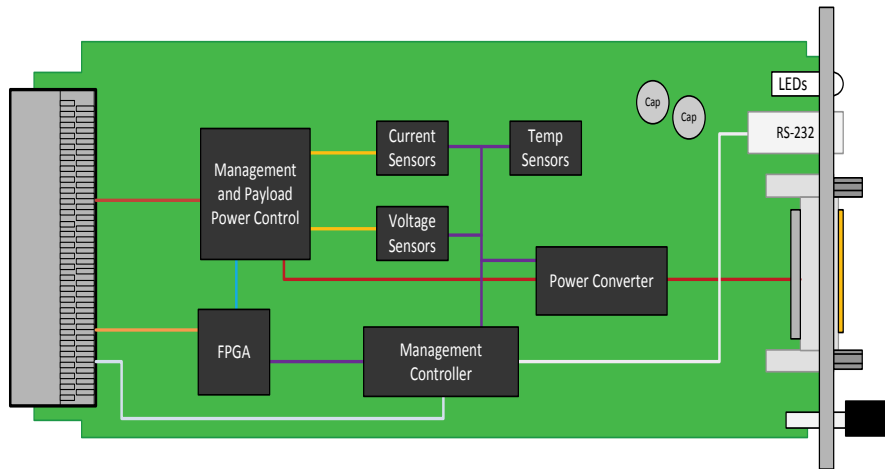

Figure 1: Block Diagram



Figure 2: Front Panel

DC Power Module, 241W or 460W – UTC014

ORDERING OPTIONS

UTC014 – A00 – 000 – GHJ

A = Input Power

- 1 = 241W (input voltage 10 to 36V)
- 2 = 460W (input voltage 18 to 36V)

G = Front Panel Type

- 0 = μ TCA.0
- 1 = μ TCA.1

H = Temperature Range

- 1 = Commercial (-5° to +55°C)
- 2 = Industrial (-20° to +70°C)
- 3 = Military (-40° to +85°C)

J = Conformal Coating

- 0 = None
- 1 = Humiseal 1A33 Polyurethane
- 2 = Humiseal 1B31 Acrylic

RELATED PRODUCTS



EXP100 Express
Development Chassis



UTC004 Gen 3
MCH



AMC720 Processor
AMC

CONTACT US

VadaTech Corporate Office

198 N. Gibson Rd,
Henderson, NV 89014
Email: info@vadatech.com
Telephone: +1 702 896-3337
Fax: +1 702 896-0332

Asia Pacific Sales Office

7th Floor, No. 2, Wenhua Street,
Neihu District, Taipei 114, Taiwan
Email: info@vadatech.com
Telephone: +886-2-2627-7655
Fax: +886-2-2627-7792

VadaTech European Sales Office

Ocean Village Innovation Centre, Ocean Way,
Ocean Village, Southampton, SO14 3JZ
Email: info@vadatech.com
Telephone: +44 2380 381982
Fax: +44 2380 381983